

# **SD Series Drives**

Operator's Manual  
PN 04-01905 A

PRECISION MOTION CONTROLS

2530 Berryessa Rd. #209  
San Jose, CA 95132

2/15/06

## Table Of Content

<b>INTRODUCTION</b> .....	<b>3</b>
<b>DESCRIPTION</b> .....	<b>3</b>
<b>FEATURES</b> .....	<b>4</b>
<b>WARRANTY</b> .....	<b>4</b>
<b>INSTALLATION</b> .....	<b>5</b>
<b>UNPACKING</b> .....	<b>5</b>
<b>MOTOR CONNECTIONS</b> .....	<b>6</b>
<b>INDEXER CONNECTIONS</b> .....	<b>9</b>
<b>SWITCH SETTINGS</b> .....	<b>11</b>
<b>MOTOR RESONANCE</b> .....	<b>11</b>
<b>CURRENT SETTING</b> .....	<b>13</b>
<b>AUTO-STANDBY</b> .....	<b>13</b>
<b>LOW CURRENT MOTOR SELECTION</b> .....	<b>13</b>
<b>TEST MODE</b> .....	<b>13</b>
<b>SPECIFICATION</b> .....	<b>13</b>
<b>ELECTRICAL</b> .....	<b>13</b>
<b>MOTOR COMPATIBILITY</b> .....	<b>13</b>
<b>INDEXER INPUTS</b> .....	<b>14</b>

## INTRODUCTION

### Description

The SD series Drive is a bipolar micro stepping drive with a Pulse Width Modulation amplifier (PWM) switching at 20kHz frequency. The drive uses DSP advanced technology and available H bridge power device to achieve high performance, low cost and reliability with very compact size. See below the simplified block diagram of the drive.

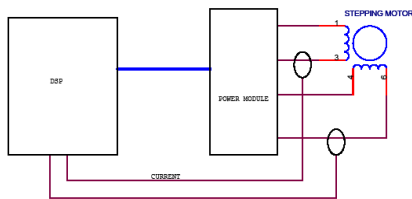

The drive regulates the current in the motor windings using three different techniques; by charging, discharging and re-circulating. It minimizes ripple current caused by the PWM to reduce the motor heating.

Two power inputs are provided for the drive. One is for logic circuit, It requires a D. C. voltage between 24V and 7.5V, minimum 100 ma current. The other is for motor power, it requires a D. C. voltage between 12V to 40V. For the voltage to supply the electronics and an external resistor to set the current for the motor. The drive can deliver 3 amps peak current at the output stages with a 24 volt supply is used. The drive is intended for use with 2 phase bipolar stepping motor applications where the cost is sensitive and space is premium. The SMD is provided with a micro stepping resolution of up to 51200 steps per revolution; this makes this product suitable in applications with precision equipment where vibration must be minimized. The drive is optimized for frame size 17, 23 stepping motors. One dipswitch is provided on board for easy selection of the step sizes, auto-shutdown, 3rd harmonic corrections, and test mode.

Step, direction, remote disable inputs and a fault output are provided to interface the drive. The disable input removes power to the motor so that it can be turned by hand. This may also be used as a safety limit since it overrides any of the other drive signals.

The drive has power up sequences to detect winding open or short conditions of the motor windings. When the motor windings are open or short, the drive 's power amplifier will be turned off. If this happens turn off the power, double check that the motor windings are not

shorted to each other and the motor wires are stripped and securely fastened to the terminal.

The drive also has current limit to protect over current condition during normal operation. The drive will shut down. Turn off power and wait for several seconds till the supply is depleted and turn on the drive again to reset the drive.

## Features

- Microstepping provides smoothness of motion
- Wave shape correction of 2%, 4% third harmonic distortion for improved smoothness
- 12 to 40 DC single supply
- Auto-standby current reduction
- 2 MHz step input rate
- 8 dip switch selectable step sizes and detent correction
- Full short circuit current protection for phase to phase and phase to ground
- Test mode

## Warranty

PMC's SMD drive has a one year warranty against manufacturing defects from the date of purchase. If your unit should ever fail, and you wish to send it back for repairs; you should do the following:

1. Get the serial number from the defective unit.
2. Check purchase date to see if the unit is under warranty. If not, obtain a purchase order number for repair costs.
3. Call Precision Motion Controls for a return authorization (408) 298-0898 or email to [service@premotn.com](mailto:service@premotn.com)
4. Ship to:

Precision Motion Controls  
2530 Berryessa Rd. #209  
San Jose, CA 95132

Attention RMA # \_\_\_\_\_

## INSTALLATION

### Unpacking

When unpacking your unit verify that the unit was not damaged during shipping. Report any damage found to the shipper. Check the box contents against the packing slip. The box will contain the driver and manual.

The drive has a dip switch selectable self test mode. For the self test mode set switches 1,2,3 to the off position, the motor will run about 0.7 revolution per second.

Connect the motor and a D. C. power supply to the drive. Select the resistor from the chart on page 7 for the desired current of your motor. Install the resistor and turn the power on. The motor should be moving about 0.7 revolution per second. Feel the shaft of the motor and verify that the motor is producing torque. If you are able to move the motor shaft the motor does not have torque; turn off the supply. Checks if the current value set by the resistor is selected correctly and the resistor is properly secured. If the fault signal is low turn off the power check the motor windings are not either open or short and the motor wires is connection is tight. Contact the factory for a return authorization if the above checks prove negative. If the above test works turn off the drive and put the unit into the non test mode by placing dip-switch 1, 2, 3 to non off position.

**CAUTION**, always disconnect the DC power prior to connecting or disconnecting the motor to the drive. Never remove the motor wires with power on. It may damage the drive.

### Mounting

The SD Drive comes with a built in mounting hole to facilitate mounting. The unit may be mounted in any direction.

### Cooling

The drive's power IC is mounted on the pcb ground plane to dissipate heat. The drive is capable of running at 3 amps, 24V DC supply and 25 degree C room temperature when 24V supply is used. When the ambient temperature is high or the drive's current is higher than 3 amp. The drive can be mounted on extra heat sink to dissipate the heat. Air circulation will also lower the heat sink temperature. The heat sink temperature must be kept at most 55 degree C at any condition to protect the power transistors.

## Motor Connections

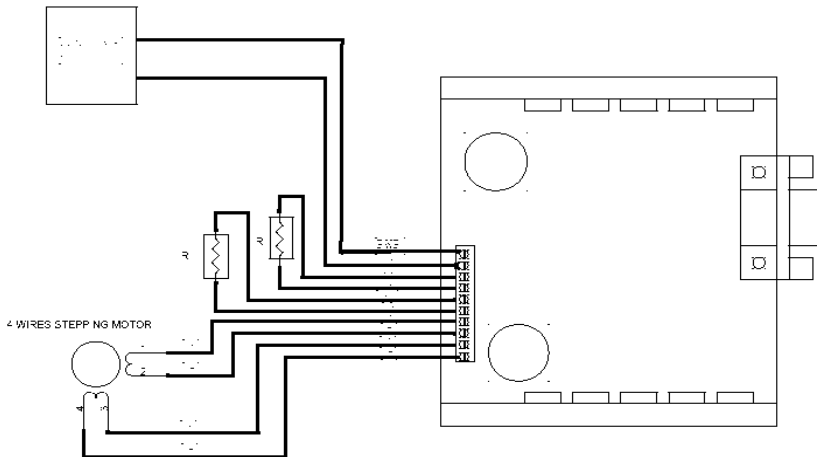

The drive has two connectors on the board; a 10 pin screw tight terminal block for power and the motor. A 9 pin "D" connector for the indexer.

The connections are in white silk screen on the printed circuit board adjacent to the terminal block for easy reference. The following explains each connection.

PWR	GND	DMP+	DUMP-	I	GND	A+	A-	B+	B-
-----	-----	------	-------	---	-----	----	----	----	----

### PWR, GND

Connect to + power supply to PWR and –power supply to GND.

### DMP, DUMP-

Connect a power resistor between Dump+ and DUMP- if the motor with heavy load requires fast deceleration. When the supply rises above 78 volt the power resistor will be connected to the supply and ground as load to dissipate energy. The power resistor value and power

rating should be evaluated carefully. The resistor should limit the current drawn to less than 3 amp. Low value resistor will draw high current from the supply to the ground and dissipate large power from the supply rail. It is used for the motor required to dissipate large amount of energy.

I, GND

The voltage across the two terminals is about 0.6 volt. Connecting a typical 1/4W or 1/8W resistor between these two terminals will set the motor peak current. The current value is determined by the resistor value based on the formula:

$$I = 0.64 (1+12K/(1K+ Rx))$$

Rx is the resistor connected between I and GND, value in ohm.

Example: when the I and GND is shorted

$$I = 0.64(1+12) = 8.32$$

Below are the selected Rx values and the current setting

Rx value	Current (A)
open	0.6
10K	1.3
3K	2.5
2K	3.2
1K	4.5
820	4.9
470	5.9
200	7.0
0	8.3

A+, A-

Connect to one pair of stepping motor winding

B+, B-

Connect to the other pair of stepping motor winding

The 2 phases stepping motors come with 4, 6 and 8 wires different configurations. There are 2 or 4 windings in the motor. For 8 wires motor, wire them in parallel or in series. Parallel motor runs higher speed than the series one but with less holding torque when the same current setting is used for the drive. For the 6 wire motor connects the center tap wire and opposite end of wire as one winding. For 4 wires connection's motors connect one winding to A+ and A-, the other winding to B+, B-.

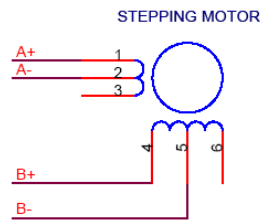
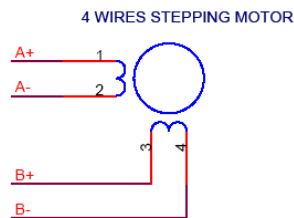
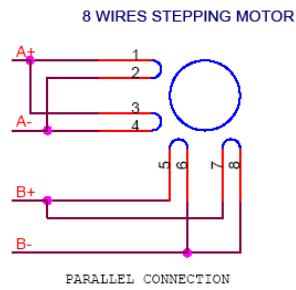
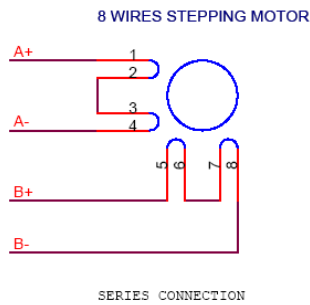

Motor companies rate their motor specification differently. Carefully read the motor specification. If the motor is run with higher than rated current the motor can get too hot and may be damaged. Even motors run at the rated current can get very hot. The motor can generate a lot of more heat in the high speed applications compared with motor standing still. It may take hours for the motor to reach thermal equilibrium. Setting motors to run about 70% of rated current to lower the body temperature is not uncommon. The motor temperature should be kept below 60 degree in any conditions.



## **Indexer Connections**

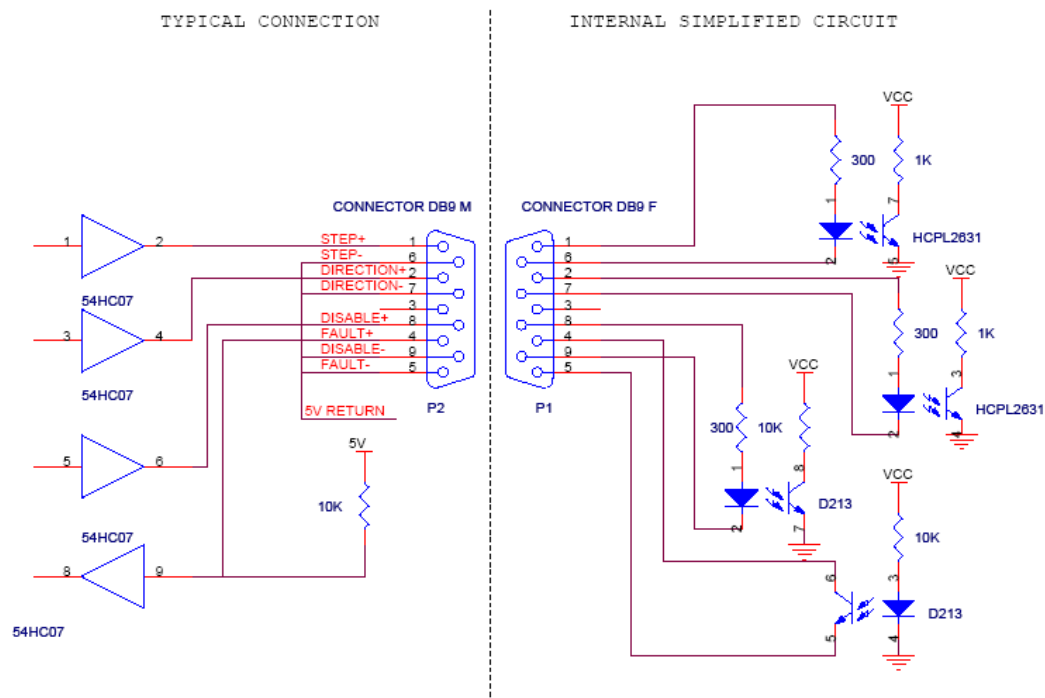

The STEP+, STEP-, DIRECTION+, and DIRECTION- signals are required for operation of the motor. These signals are photo-coupled to eliminate ground loops. The direction signal must not change 50 usec. prior to the step signal changing. A remote shutdown input is provided to remove power from the drive without removing DC power from the drive.

If an over-current condition is detected the photo-transistor across the Error+ and Error- output is turned on. If the ERROR signal is active, the drive's DC power needs to be recycled to reactivate the drive.

The Error condition is satisfied if the drive's output is shorted.

9 pin "D" connector

- 1 Step +
- 6 Step -
- 2 Direction +
- 7 Direction -
- 8 Shutdown +
- 9 Shutdown -
- 4 Fault + (collector)
- 5 Fault - (emitter)
- 3 no connection

### Switch Settings

Disconnect power from the unit prior to attempting to change any switch settings. The switch settings control the step size of the motor\driver, 3rd harmonic corrections, test mode and standby mode. The switch only reads after power up. Any changed during normal operation has no effect until after the power is recycled.

The dip switch is accessible from the board. The following diagrams and tables list the switch settings for various motor currents and micro-stepping resolution. Resolutions not listed may be ordered as specials. Normally 0% harmonic should be selected. If you notice the motor vibration is high when running, try different harmonic may reduce the vibration.

3 harmonic	Switch 1	Switch 2	Switch 3
0%	0	0	0
2%	1	0	0
-2%	0	1	0
4%	1	1	0
-4%	0	0	1
6%	1	0	1
-6%	0	1	1
test	1	1	1

### Motor Resonance

Stepping motors have resonant problems due to their mechanical structure. The motor can skip steps in full step mode. Selecting a high resolution per revolution setting reduces the resonance significantly. The motor resonance is around 0.5, 1, 2 revolution per second.

Steps per revolution	Switch 4	Switch 5	Switch 6
1000	0	0	0
5000	1	0	0
25000	0	1	0
50000	1	1	0
3200	0	0	1
6400	1	0	1
12800	0	1	1
25600	1	1	1

selection	Switch 7	Switch 8
standby	1	x
Low current motor	x	1

### **Current Setting**

The motor current is set by an external resistor.

### **Auto-Standby**

In the auto-standby mode the drive reduces the current to 1/2 the rated current after approximately 2 seconds if no input pulses are received. This can be used to minimize motor and drive heating about 75%.

### **Low Current Motor Selection**

Select this switch when motor running current is below 1 amp. This selection increases the loop gain to improve motor running at high speed.

### **Test Mode**

This is a mode that is entered upon power up if switch 2-7 is in the on position. The motor will rotate in the CCW direction at 0.5 rev/sec. Power must be turned off and switch 2-7 put in the off position to leave this mode.

### **Specification**

#### **Electrical**

Input Power: 24V to 60 V D. C. typical 80 V maximum.

Fuse: 5 Amp (located on PC board).

Output Power: 0.5 to 6 Amps at each winding.

#### **Motor Compatibility**

The drive will run with stepping motors with minimum 1mH and maximum 40 mH inductance motor. The motors with 8 wires can be configured as parallel motors or series motors. When configured as parallel the inductance doesn't change but current can be doubled. When in

series the inductance is 4 times as individual winding. Series motors can have higher torque than parallel motor, but parallel motor can run higher speed.

## **Indexer Inputs**

Input signals: Step signals have a maximum of 2 MHz rate and a 250 nsec minimum width.

Direction signal applied at least 50 usec prior to a step pulse.

Shutdown requires 1 msec to respond (the application of this signal will cause the motor to lose sync if the step signal is applied at the same time).

Fault (error+, error-) is a npn transistor photo-coupled output. The transistor is on when an over-current condition is detected.

All input signal are optically isolated and have a 330 ohm current limiting resistor in series. A current of 8 to 15 ma should be applied to the opto-couplers. A driving source of 5 volts will meet this requirement.

"DO Not" connect or disconnect the motor with power applied to the box.

